

▲ Sleep Pod.

For dreams of a better future

Please follow the build instructions carefully.
Remember, someone will be sleeping in it outside.
A well made Sleep Pod will keep someone warmer, dryer
and last for much longer.

STAGE 1

REMEMBER

▶ APPLY FIRM PRESSURE, RUB AND WARM TAPE REPEATEDLY TO ACTIVATE ADHESIVE

TAPE END OF PANELS

1.1
take two panels
of bubble foil

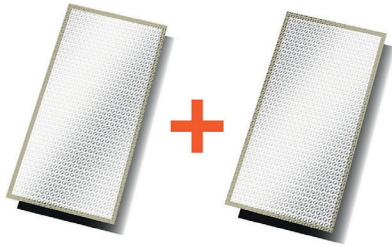

1.2
place tape over the short end
of one of the panels

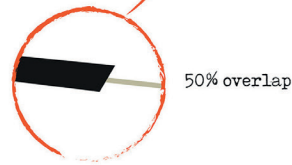
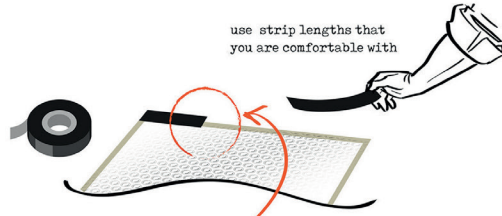

1.3
fold to create seal
apply pressure and rub to
activate adhesive



tape adhesive
is activated by the
heat generated
from rubbing

1.4
repeat
until all 4x
short ends are
sealed with
black tape

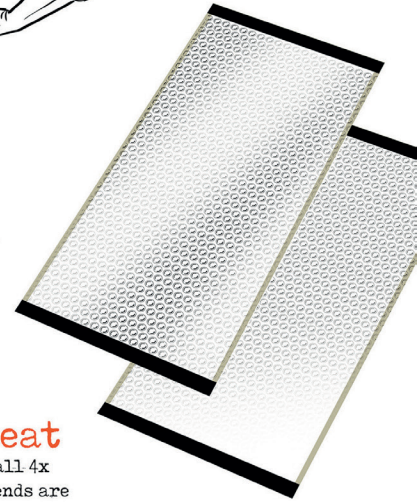

STAGE 2

REMEMBER

▶ APPLY FIRM PRESSURE, RUB AND WARM TAPE REPEATEDLY TO ACTIVATE ADHESIVE

TAPING THE MIDDLE

2.1
place panels
side by side

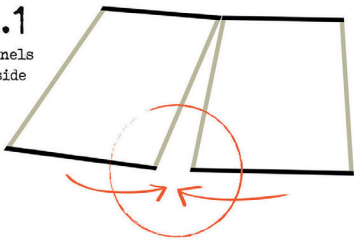

2.2
tape panels
together
with black
tape

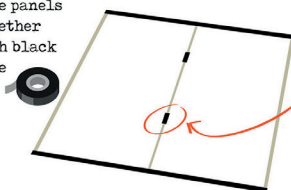

fix panels
together with
a couple of
small pieces
of tape...

2.3
...then tape over
full length of panel
with 3-4x longer strips

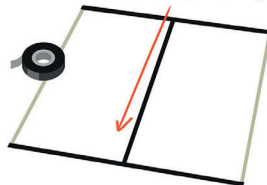

2.4
flip

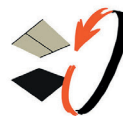

2.5
use one long strip
of aluminium
foil to seal the
remaining split

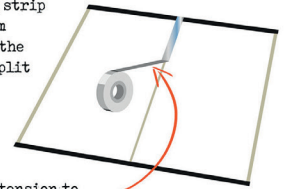

use tension to
create smooth
& straight line
of aluminium tape

2.6

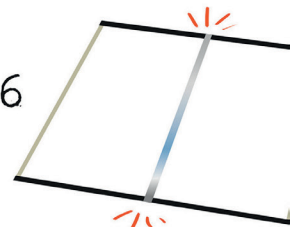

Make sure both panels are fully touching
along the long edge and that they are
aligned well at both ends before applying
the full length of tape.

STAGE 3

DON'T FORGET

▶ THE ALUMINIUM FOIL IS AT THE TOP OF THE POD

FOLD & TAPE

3.1
fold panels together

ensuring that aluminium foil is on the inside

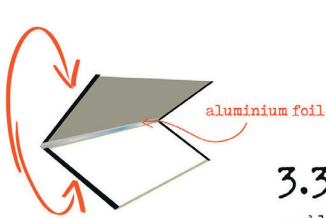

3.3
run black tape to join remaining unsealed long edge

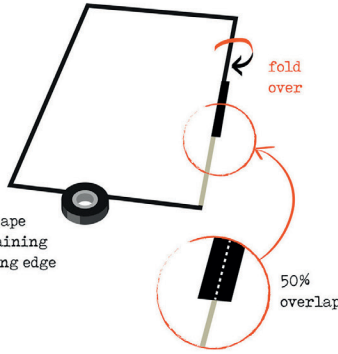

3.2
make sure the edges are aligned

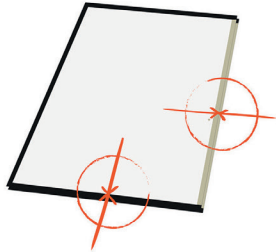

3.4
make sure aluminium foil is on the inside! This will be the top of the pod.

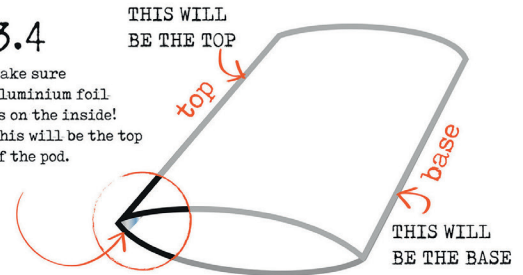

STAGE 4

REMEMBER

▶ FIX BAMBOO CANES TO THE TOP EDGE OF THE POD

BAMBOO STRUCTURE

This stage is the **MOST** important stage of the build, if it is not done correctly the pod will fail.

4.1
get 6x bamboo canes

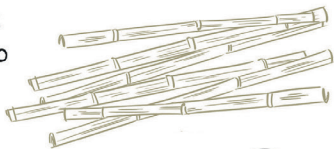

find the middle of the panel by folding in half

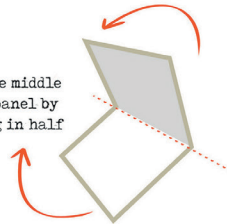

4.2
ESTABLISH THE TOP EDGE

Remember the top edge will have aluminium tape on the inside.

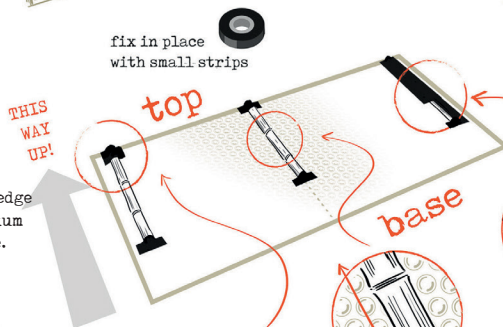

4.3
fix 3x bamboo canes to one side, with one end flush to the top edge of panels

ensure bamboo is flush to edges

aluminium foil

2 cm gap

use bubbles as a guide

double tape thickness



make sure ends of bamboo are sealed at top edge



align bamboo on both sides

4.4
flip and repeat on the other side

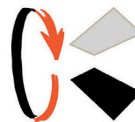

▲ Sleep Pod.

For dreams of a better future

Please follow the build instructions carefully.

Remember, someone will be sleeping in it outside.

A well made Sleep Pod will keep someone warmer, dryer and last for much longer.

STAGE 5

DON'T FORGET

TAP ON THE TOP OF THE POD TO ENSURE THE BAMBOO IS TOUCHING THE FLOOR

OPEN THE POD

5.1 open out

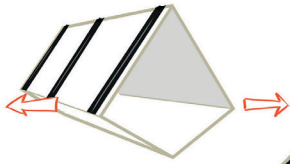

5.2

tap down to ensure that bamboo touches the floor



5.3

press and smooth out the edges of pod base



5.5 apply foil tape along inside split line

Applying this tape is tricky, you need to apply some tension to the tape, it is much easier with two people so that the tape can be passed from one person to another.

5.4 flip

and repeat on the other side

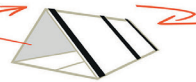

the pod is up and the floor sealed

and we're over half way there!

STAGE 6

IMPORTANT

WHEN THE FRONT DOOR IS IN POSITION THE VELCRO WILL NOT BE VISIBLE

FRONT DOOR

6.1

get front door panel

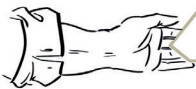

top

this way up

6.2

add velcro (hook/rough) x2 to door panel

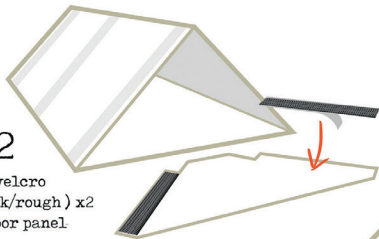

6.3

and insert panel into pod...

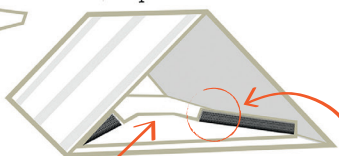

fold velcro tabs inwards

6.4

apply tape sticking the door to the pod base

2cm gap



2cm = approx 2x finger-widths

6.5

flip out

fold velcro tabs inwards

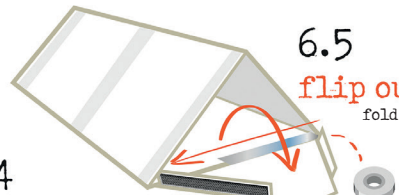

6.6

...and seal over base of inner door with aluminium tape

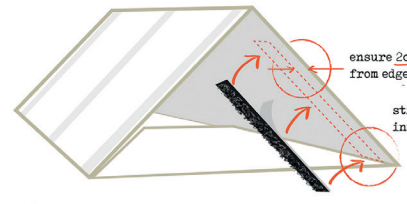

6.7

fold door back in

6.8

and add velcro (loop/smooth) x2 to inside walls

VELCRO ADHESIVE TAKES 24 HOURS TO SET

(so avoid sticking hook & loop together too soon!)



It is critical that the door goes into the pod the right way round with the velcro strip facing up when the door is lying flat inside the pod. This is so that the door can be closed and fastened from the inside of the pod.

STAGE 7

DON'T FORGET

▶ **TAPE BACK PANEL 5CM FROM THE EDGE OF POD**

BACK PANEL

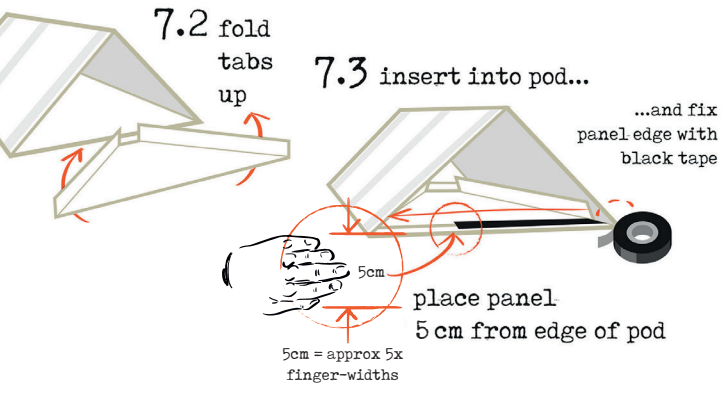
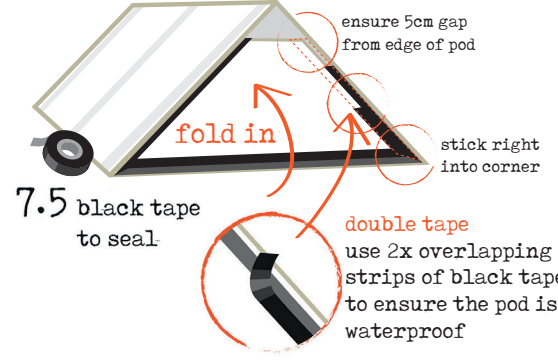
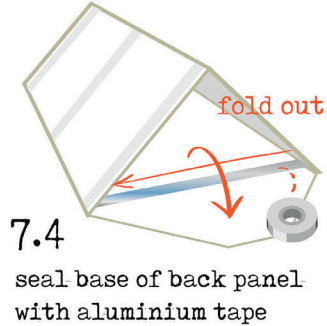
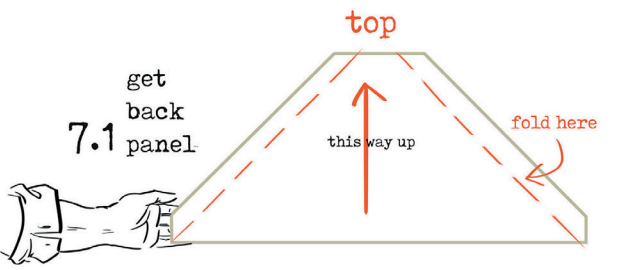

7.6 create a rainwater run-off

Its **REALLY** important that rainwater flows away from the pod

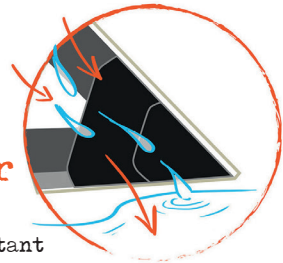

STAGE 8

REMEMBER

▶ **TO FOLD THE FRONT DOOR INSIDE THE POD**

FOLD & BAG

